

# CRANSTON

## MACHINERY CO. INC.

### MODEL 26A086 3 M.T. S.W.L. UNI-HOOK

**180 Degree Limited Swivel**

***Reduce labor by eliminating manual unlocking of the load.***



Cranston's model 26A086, 3 M.T. 180-degree swivel cap, UNI-HOOK is a pneumatically unlocked lifting hook designed specifically for top attachment lifting and is most commonly used with multiple spreader bars or lifting frames.

The Uni-hook is manually attached to the lifting strap and then once in the unloading location, pneumatically unlocked from a remote location, typically with a manual striker plate or electric solenoid.

The 180-Degree Swivel Cap allows a limited degree of free alignment capabilities yet helps prevent excessive twisting of the support chain and air supply line. Special care to assure proper alignment of the lifting strap must be provided by the user.

Acceptable applications can be multiple strands of wire, wire ropes, steel rings, fabric slings, or flat steel slings. All must be carefully reviewed and tested.

Contact Cranston Machinery for a free copy of:

- Cranston's "Guidelines for cargo lifting with Cranston's UNI-HOOK", specification #CS005"
- Cranston's "UNI-HOOK operating instructions", Bulletin #L022.

The Model 26A087 hook and latch offer a 25mm (1") high opening and are constructed using high strength corrosion resistant materials.

Upon pneumatic unlocking, the hook can be pivoted open to release the load.



***Corrosion resistant  
Large Opening Hook & Latch***

# UNI-HOOK

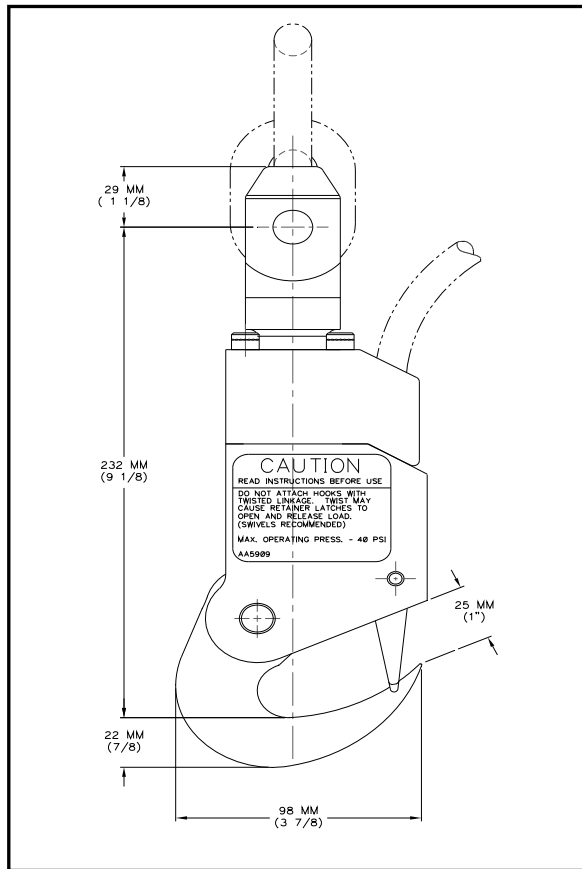

**Features:**

- Saves Labor costs.
- Simple to operate and maintain.
- Rugged design proven in Maritime use.
- Designed to 4:1 safety factor.
- Factory tested and certified (Manufacturer's proof load test).
- Corrosion resistant cap, body, hook and latch.
- Individually serialized.

**Specifications:**

- Capacity: 3 MT (6615 lbs.) max. Safe working load.
- Size: 98mm (3-7/8") wide x 54mm (2-1/8") thick x 285mm (11-3/16") tall
- Weight: 4.98kg (11lbs.)

**Requirements:**

- Pneumatic supply: 18.0 CC (1.1 cubic inch) at 2.5-2.85 BAR (35-40 PSI) free air or nitrogen per cycle.
- Pneumatic fitting: 1/4"NPT.
- Lifting chain: 1/2" grade 8 link chain (5/8" diameter pin is included for connection of hook to customers chain).

**Alternate models**



UNI-HOOK  
3MT Fixed Cap  
Model 26A090



WEB-LATCH  
5 MT Model: 26A081  
10 MT Model: 26A083



UNI-LIFT  
2 MT  
Model 26A069



Upgrade kits or Complete Custom  
Designed Lifting Frames.



**FOR FURTHER DETAILS CONTACT:**

**Cranston Machinery Co., Inc.**

2251 SE Oak Grove Blvd., Oak Grove, OR. 97267

Phone: 503-654-7751 Fax: 503-654-6172

[www.cranston-machinery.com](http://www.cranston-machinery.com)

All products and services are covered by Cranston standard terms and conditions, including Limits of liability and warrantee effective at the time of sale. Available upon request.

Brochure # L023 090625