

CRANSTON

MACHINERY CO. INC.

MODEL 26A092 3 M.T. S.W.L. UNI-HOOK

Reduce labor by eliminating manual unlocking of the load.

Cranston's model 26A092 UNI-HOOK is a pneumatically unlocked lifting hook designed specifically for top attachment lifting and is most commonly used with multiple spreader bars or lifting frames. The Uni-hook is manually attached to the lifting strap and then once in the unloading location, pneumatically unlocked from a remote location, typically with a manual striker plate or electric solenoid.

This model is Cranston's newest standard UNI-HOOK. It offers unsurpassed flexibility, a rating of 3 Metric ton (Safe Working Load), a 360-degree swivel cap and Cranston's Corrosion resistant large opening hook and latch.

Acceptable applications can be multiple strands of wire, wire ropes, steel rings, fabric slings, or flat steel slings. All must be carefully reviewed and tested.

Contact Cranston Machinery for a free copy of:

- Cranston's "Guidelines for cargo lifting with Cranston's UNI-HOOK", specification #CS005"
- Cranston's "UNI-HOOK operating instructions", Bulletin #L036.



The Model 26A092 hook and latch offer a 25mm (1") high opening and are constructed using high strength materials.

Upon pneumatic unlocking, the hook can be pivoted open to release the load.



Wear resistant Large Opening Hook & Latch

UNI-HOOK

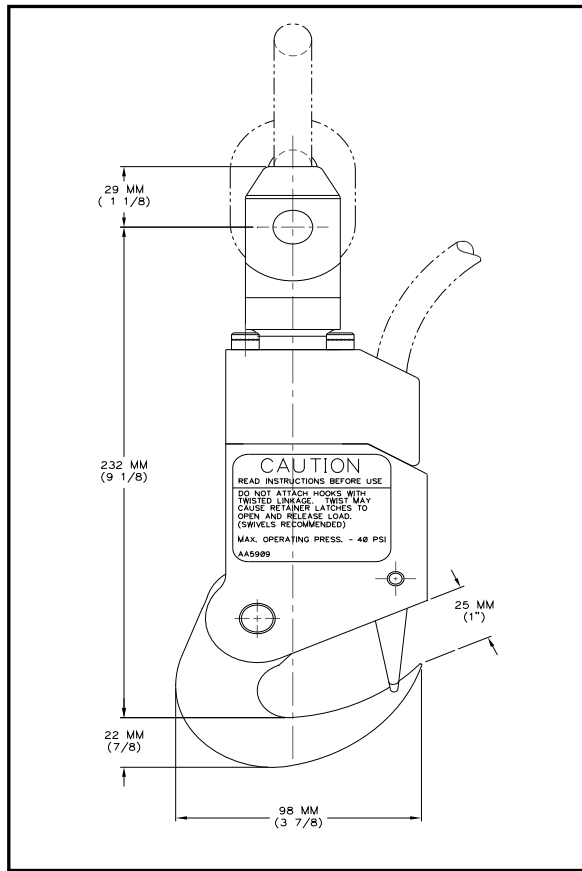

Features:

- Saves Labor costs.
- Simple to operate and maintain.
- Rugged design proven in Maritime use.
- Designed to 4:1 safety factor.
- Factory tested and certified (Manufacturer's proof load test).
- Corrosion resistant cap, body, hook and latch.
- Individually serialized.

Specifications:

- Capacity: 3 MT (6615 lbs.) max. Safe working load.
- Size: 98mm (3-7/8") wide x 54mm (2-1/8") thick x 285mm (11-3/16") tall
- Weight: 4.98kg (11lbs.)

Requirements:

- Pneumatic supply: 18.0 CC (1.1 cubic inch) at 2.5-2.85 BAR (35-40 PSI) free air or nitrogen per cycle.
- Pneumatic fitting: 1/4"NPT.
- Lifting chain: 1/2" grade 8 link chain (5/8" diameter pin is included for connection of hook to customers chain).

Alternate models



UNI-HOOK
3MT Fixed Cap
Model 26A090



WEB-LATCH
5 MT Model: 26A081
10 MT Model: 26A083



UNI-LIFT
2 MT
Model 26A069



Upgrade kits or Complete Custom
Designed Lifting Frames.



FOR FURTHER DETAILS CONTACT:

Cranston Machinery Co., Inc.

2251 SE Oak Grove Blvd., Oak Grove, OR. 97267

Phone: 503-654-7751 Fax: 503-654-6172

www.cranston-machinery.com

All products and services are covered by Cranston standard terms and conditions, including Limits of liability and warrantee effective at the time of sale. Available upon request.

Brochure # L036 090625