

CRANSTON

MACHINERY CO. INC.

EZ Thread Wire Coil Cage



Features that make a difference!

- ***New EZ thread system makes wire threading easier and faster!***
- ***Designed for Bale, Stack and Unit wire!***
- ***Total wire containment!***
- ***System is standard for portable applications and available for fixed applications!***

Standard On all Cranston bale strappers, stack strappers and Unitizers

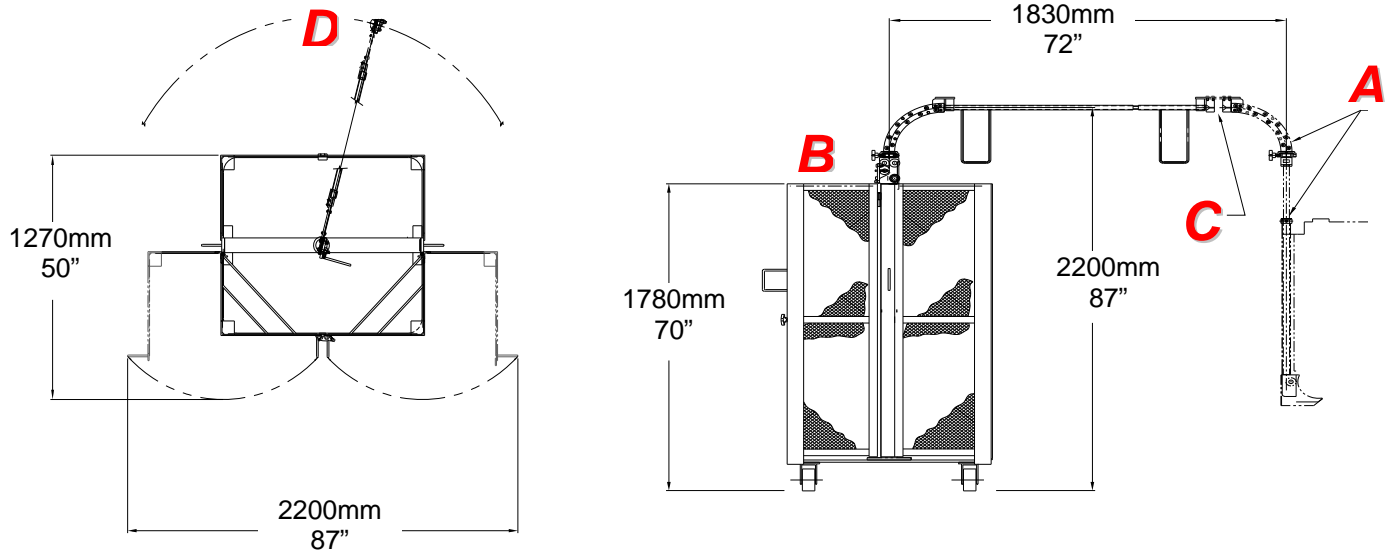

The EZ thread system includes:

- Tapered guides that allow simple pushing of the wire into the receiver opening.
- Quick release adjustable wire straightening wheel for breaking the wire cast,
- An adjustable gooseneck and telescoping cross tube for flexible positioning of cart.

Options

- Fixed Cage Kit, includes base to mount complete cage directly to floor. Cart remains portable or can be deleted.
- Pipe stand for customers receiving wire orbits.

Specifications

- Standard package includes the cart with cage, two anti-fouling arms, payoff ring, Gooseneck and cross bar. Assembly required.
- System is sandblasted, primed and painted Black enamel.
- Weight (empty): 295KG (650 LB)
- Approximate shipping size: 1200mm (48") long x 1220mm (48") wide x 1981mm (78") high.
- Wire Diameter: 3.14mm(10.75awg) to 1.83mm (15awg)
- Coil Size: 890mm (35") max. OD x 1016mm (40") max height

Requirements:

- Smooth operating floor
- Wire Strapper equipped with Cranston's EZ thread system.

A. The machine side of the EZ thread wire system is supplied on new strapper's and Unitizers. Retrofit kits are available for most earlier Cranston model machines.

B. 50B019 - Retro Kits include the EZ thread wire infeed (machine side), cross tube, cart gooseneck and cages for attachment to existing 50B series carts. (minor modifications to your existing cart is required).

C. Opening for access to cut wire and separate cart from machine.

D. Gooseneck and crossbar are capable of full rotation.



Optional Pipe Stand

**FOR FURTHER DETAILS CONTACT:
Cranston Machinery Co., Inc.**

2251 SE Oak Grove Blvd., Oak Grove, OR. 97267
Phone: 503-654-7751 Fax: 503-654-6172

www.cranston-machinery.com

All products and services are covered by Cranston standard terms and conditions, including limits of liability and warranty effective at the time of sale. Available upon request.



Technical Specification T035 090810