



Cranston Specification: **CS006**  
Formatting updates: 07182023  
WEBLATCH™ Models: All

## CRANSTON Specification #CS-006

### Guidelines for cargo lifting with Cranston Machinery WEBLATCH™ HOOKS

## TABLE OF CONTENTS

1.0 The Purpose of this Specification.....	1
2.0 A Brief History and Background.....	2
3.0 WEBLATCH™ Models.....	2
4.0 Hook Set-up and Use.....	3
5.0 WEBLATCH™ Hook Inspection and Repair.....	3
6.0 Safe Working Load / Factor of Safety.....	4
7.0 The Effect of Angular Pulls.....	4
8.0 Suggested Instructions for Stevedores and Longshoremen.....	5
9.0 Cargo Hook arrangements.....	6

**ATTENTION-** The use and maintenance of cargo handling gear is outside Cranston Machinery’s control. Therefore, the user must conduct his own evaluation, under the conditions of his normal use and to the safety factor pertinent to his industry, to verify the safe application of Cranston Machinery hooks with his application. Refer to individual hook model bulletins for limited warranty and limitation of liability.

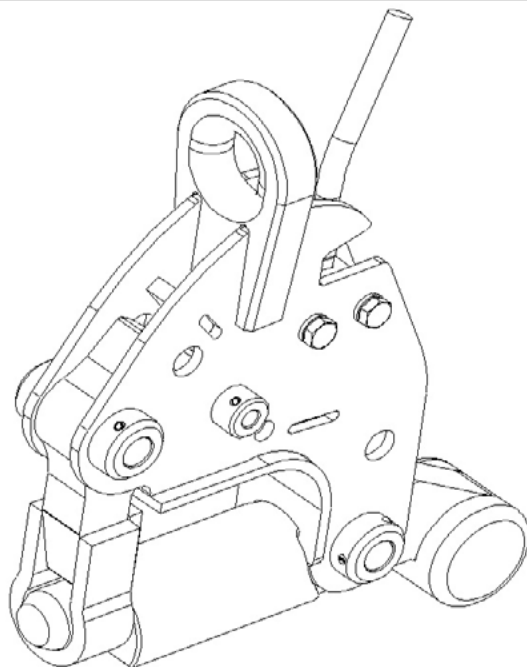

### 1.0 The Purpose of this Specification

Is to define the methods and requirements for the use of Cranston Machinery Co. WEBLATCH™ Cargo Hooks. While the subject is an integral part of the broad field of Cargo Rigging, the user is referred to the publications of specialists in rigging for other equipment, methods, and cautions.



## **2.0 A Brief History and Background**

Cranston Machinery Co. Cargo Hooks have been developed to enable the user to easily engage and disengage the media utilized to lift and move cargo. The designs, material specifications, manufacturing methods, functional components, and hook shapes have been continually studied, tested, improved and customized.

The current 5 MT and 10 MT WEBLATCH™ models are friendly to most webs and slings in straight lifts.

Cranston Machinery Co. hooks are generally designed for tandem (double hook) applications, with cargo specific spreaders or lift beams. Single hook applications are also possible, but all must be planned, tested, and documented in accordance with local regulations and accepted industry practice.

In addition to Cranston's UNIHOOK™, WEBLATCH™ and UNILIFT™ hooks, Cranston Machinery designs and manufactures custom lift beams and spreader bars complete with controls and all hook components for a lifting system to customer specifications.

## **3.0 WEBLATCH™ Models**

WEBLATCH™ models and general applicability to certain lifting media are listed below. Model 26A054 UNILATCH (7MT SWL) is in use, but no longer being produced. The WEBLATCH™ must be supported by a swivel if the sling imparts a twist on the hook. Models used with flat steel strapping or webbing must be used within the manufacturer's specifications and instructions, including those related to damage, load limits, bridle angle, connections, and arrangement.

**26A083 10 MT  
WEBLATCH™ - Red**

**26A081 5 MT  
WEBLATCH™ - Yellow**



Model	SWL (MT)	Swivel Included	Type of top Connection	Applications			
				Webbing	Chain Slings Links/Rings	Steel Strapping	Wire Rope
26A054	7	No	Eye	Up to 4" W.*	Yes	Yes *	Yes
26A081	5	No	Eye	Up to 4" W.*	Yes	Yes *	Yes
26A083	10	No	Eye	Up to 4" W.*	Yes	Yes *	Yes

\* See par. 3.4 related to use of WEBLATCH™ models with webbing and strapping



## 4.0 Hook Set-up and Use

- 4.1 The Cranston Machinery WEBLATCH™ models can be opened either with a manual release or with the remotely actuated pneumatic system. The WEBLATCH™ must be open to receive the lifting media, then the main pin is lifted as the latch is closed and locked in the latched position. The load must not be allowed to ride against the latch. After the load is positioned, the cargo weight on the hook must be completely relieved before the air pressure to the release is actuated to open the WEBLATCH™, disconnecting the lifting media.
- 4.2 Support chain and links of a size and SWL appropriate to the cargo hook SWL must be attached per the manufacturer's instructions. Under load, the hook must be able to swivel to the orientation of the gear securing the load, so the hook support chain when under load does not twist the lifting media against the latch. If the hook has no swivel attachment, the user must insure by inspection that the hook hangs freely to prevent this twist.
- 4.3 WEBLATCHES™ unlatch by means of a pneumatic cylinder. The instructions specify the minimum and maximum operating gas pressure. Compressed air or pressurized nitrogen (from a cylinder) is used to provide gas pressure to unlock the device. The supply hose must be routed and attached to the hook in a way that does not allow the hose to be twisted or fouled during use of the hook. At each attachment to a load, the hose position should be visually confirmed.
- 4.4 When the release is actuated on the WEBLATCH™ models, the mass of the pin is sufficient to open the mechanism to attach to a load. To close the mechanism, the main pin must be lifted to the closed position, and the latch closed over it, until the spring-loaded latch pawl engages. This is confirmed visually through ports on either side of the WEBLATCH™.

## 5.0 WEBLATCH™ Hook Inspection and Repair

- 5.1 Maintenance of WEBLATCH™ models consists of inspection before each use, and periodic disassembly, inspection, and lubrication, per the maintenance instructions included with the WEBLATCH™. Any components found worn or damaged should be replaced before further use of the assembly. See the parts details and lubrication requirements provided with the WEBLATCH™ assembly.
- 5.2 The WEBLATCH™ may be inspected and repaired by trained technicians or mechanics using the required tools, procedures, and lubrication. Parts are available upon request. Cranston Machinery offers hook inspection and repair with OEM parts, when hooks are returned to Cranston Machinery.

The tabulated measurements show the nominal "A" dimension of the lift eye of Cranston Machinery WEBLATCH's™ as manufactured. An increase in this measurement of .02" (1/2 mm) indicates that the assembly has severe wear or has been overstressed by at least 4 times the Safe Working Load, and the WEBLATCH™ should be replaced.

HOOK	DIMENSION "A"
26A054	1 3/8" (35mm)
26A081	1 1/4" (32mm)
26A083	1 1/2" (38mm)

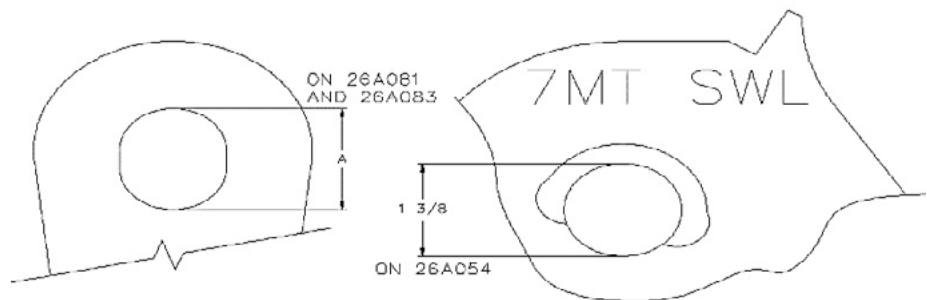



## 6.0 Safe Working Load / Factor of Safety

- 6.1 **Safe Working Load (SWL)** rating for Cranston Machinery Hooks is based on the straight pull applied to the hook. All load "below the hook" is additive to the product load being handled. Per OSHA regulations, each hook is clearly marked with the SWL.
- 6.2 The proper **Factor of Safety** for cargo handling equipment is specified by governing agencies of a given locality and may vary with many factors. Cranston Machinery Co. Cargo Hooks are designed with a **Minimum Factor of Safety of 4:1**. Thus the minimum Safe Working Load is one quarter of the minimum ultimate strength of the hook or mechanism, based on design stresses and actual destructive tests. **CHECK WITH LOCAL AUTHORITIES REGARDING THE REQUIRED FACTOR OF SAFETY FOR YOUR EQUIPMENT AND PROCEDURES.**

## 7.0 The Effect of Angular Pulls

The following diagram illustrates how, in multiple hook lifts, the geometry effects the load applied to the hook and the unit binding media.

- 7.1 The **Bridle Angle** effects the stress in the unit binding media (ie. Unitizing wires, slings, straps, wire ropes) and must be planned by the producer of the unit and considered by all subsequent handlers of the unit. Cranston Standard CS001 provides guidance in this planning for multiple strand unitizing wire.

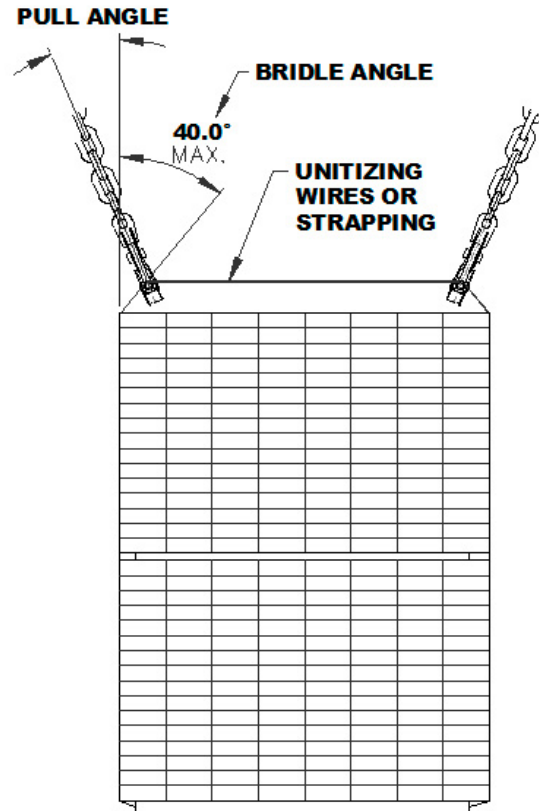

- 7.2 The **Pull Angle** directly effects the load applied to the WEBLATCH™. When using two hooks on a common unit binding media each hook bears half the unit weight if there is no pull angle. With a pull angle of 40 degrees, the load on each hook is half the unit weight divided by .776, or 30.5% more. The table below the diagram provides a factor, the cosine of the angle, for angles between 5 and 40 degrees.

PULL ANGLE	5	10	15	20	25	30	35	40
<b>FACTOR</b> (Cosine of Angle)	0.996	0.985	0.966	0.940	0.906	0.866	0.819	0.766
<b>RESULTANT HOOK LOAD</b>	100.4%	101.5%	103.5%	106.4%	110.4%	115.5%	122.1%	130.5%



## **8.0 Suggested Instructions for Stevedores and Longshoremen**

- 8.1 When using Cranston Machinery Cargo Hooks, observers are forbidden to stand under or near a hanging unit, or within the fall area of a moving load.
- 8.2 When using Cranston Machinery Cargo Hooks, all hook riggers must be clear of the load before lifting of the unit commences, and clear of the fall area of the load. Likewise, all individuals must stand clear until the load is relieved from the hooks and is completely at rest. (Crane or load may swing or shift without warning).
- 8.3 When loading or unloading, only one crew is to work in a cargo space unless work areas are properly guarded to confine multiple crews to their own work area.
- 8.4 When using Cranston Machinery Cargo Hooks, any unit with missing or damaged lifting wires or straps must be lifted with extreme caution to the point where it can be lifted out with a wire rope sling.
- 8.5 When lifting or lowering with Cranston Machinery Cargo Hooks, sudden acceleration and braking of the crane must absolutely be avoided. Cranes which permit "free-running" lowering of the load are not permitted to be used. The operator must gently take the slack out of all lift components, to allow visual confirmation that proper hook connections or disconnects have been made.
- 8.6 Cranston Machinery has no responsibility for the tools or crews used or activities of individuals involved in attaching or releasing units to or from Cranston Machinery Cargo Hooks. Local regulations and safety precautions must be followed.
- 8.7 All individuals involved in the use, inspection and maintenance of cargo handling equipment must be properly trained and authorized.

## 9.0 Cargo Hook arrangements

The following drawings show some acceptable and unacceptable cargo hook and unit arrangements. These apply to Cranston Machinery WEBLATCHES™, as well as other Cranston Machinery Hooks, applied according to hook SWL and lifting media limitations.

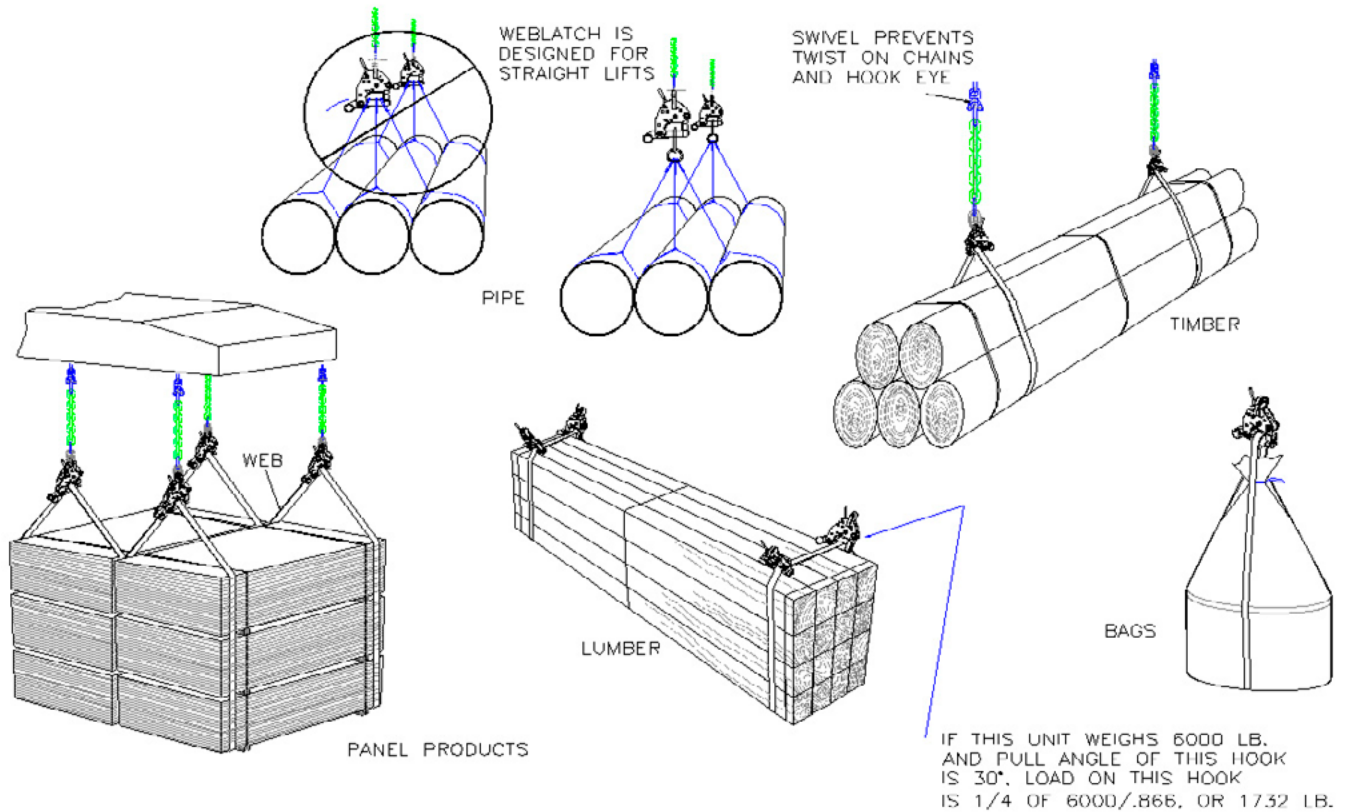

**ATTENTION-** The use and maintenance of cargo handling gear is outside Cranston Machinery's control. Therefore, the user must conduct his own evaluation, under the conditions of his normal use and to the safety factor pertinent to his industry, to verify the safe application of Cranston Machinery hooks with his application.

Refer to individual hook model bulletins for limited warranty and limitation of liability.