



Bulletin No:	L045
UNIHOOK™ Model:	26A097
Issued:	211129

Introduction:

The Cranston UNIHOOK™ is a very robust, marine grade, lifting device, designed to provide remote release of a pre-slung load.

The user must assemble the UNIHOOK™ to a properly rated chain assembly and plumb to a pressurized, regulated air or nitrogen supply.

During attachment to a lifting sling (multiple wire strands, wire ropes, slings, rings, etc.), the pivoting hook is manually cocked in the locked position.

To unlatch the pivoting hook from the locked position, the load must be removed from the hook before the pneumatic supply is applied. For relocating slings, or other similar light load applications (up to 23Kg/50#), the pivoting hook can be released.

Limitation of Liability. Rigging, conditions of use, and maintenance of cargo handling gear is outside of Cranston Machinery Control. The user, therefore, must evaluate each application under the condition of use and the safety factor pertinent to the appropriate industry, to determine the safe application of the Cranston Machinery UNIHOOK™

Specifications:

- Safe Working Load: 3 Metric Tonnes
- Design Safety factor: 4 x SWL
- Certified Testing for each UNIHOOK™: 2 x SWL
- Operating Temperature: -35°C - +175°C
- Typical Weight: 5kg / 11#
- Guidelines for Maintenance, Use and Care: **CS005**
- Top Cap Features: **360 Degree rotation**
- Pivoting hook Material choice: **Wear resistant**
- CE Compliance: Yes
- Tested for Underwater release: Yes

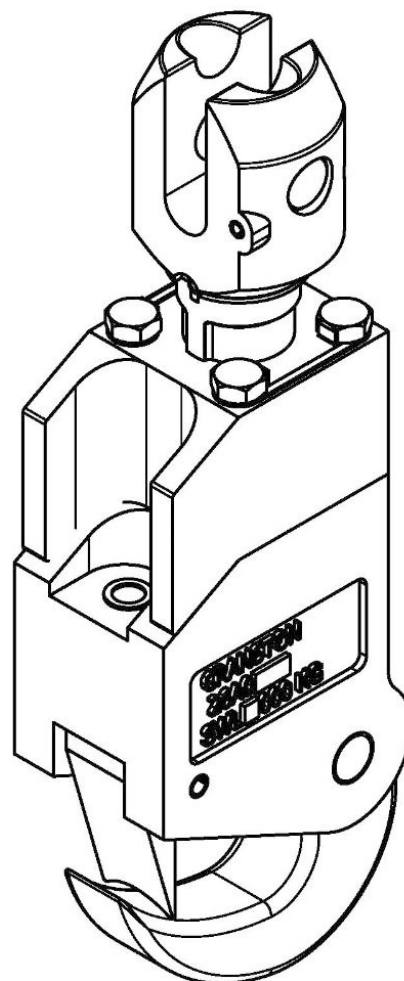

ATTENTION- All owners, users and technicians should review Cranston Specification CS005 prior to operation or servicing of this UNIHOOK™. CS005 is available thru the adjacent QR code and Cranston's website. CS005 includes detail on use, maintenance, and warranty

WARNING- It is imperative that the pressurized pneumatic supply does not exceed .28MPa / 40PSI.

NOTE- Cranston Machinery would be pleased to consider any special requirements you may have. Cranston Machinery designs and manufactures custom tools, lift beams and automated equipment.



Item / Qty / Part No. / Description

01	1	CB4226000	Swivel attachment
02	1	CA8709000	Top cap
03	1	CB6509000	Body
3A	1	M53100102	Plug, 1/4" NPT
04	1	CB5417000	Hook
05	1	AA7842000	Hook pin
06	1	M69100002	• Latch pin
07	1	CA3139000	Piston
08	2	M57000001	• U-Cup seal
09	1	M57000002	• U-Cup seal
10	1	AA8451000	Spring
11	1	AA8777000	Swivel bolt
12	1	AA8778000	Swivel bolt washer
13	4	M30600005	• Tie bolt
14	2	M69100032	• Roll pin
15	1	AA4197000	• Spring latch
16	1	BB6654000	Latch
17	1	M30100013	Set screw
18	2	BB8401000	• Bolt locking tab
19	1	M30100013	Jam set screw
20	1	AA6223000	Chain pin
21	1	-----	apered plug
22	1	AA5909000	Caution sticker

• Recommended Spares

Warning- Only use #M30600005 Bolts. They are special high strength bolts. Do not substitute any other hex head bolts.

ATTENTION- Cranston assembles each hook using a NLGI #2, marine grade, calcium sulfonate base grease (Example: Lucas Marine Grease) which seals out water and inhibits corrosion. Any substitution must be NLGI #2, have a washout rating of less than 3% (typically Calcium Sulfonate or polymerized PTFE), and a viscosity of 120-220 cSt. Ensure grease not applied to threaded areas. Stars in diagram indicate lubrication points.

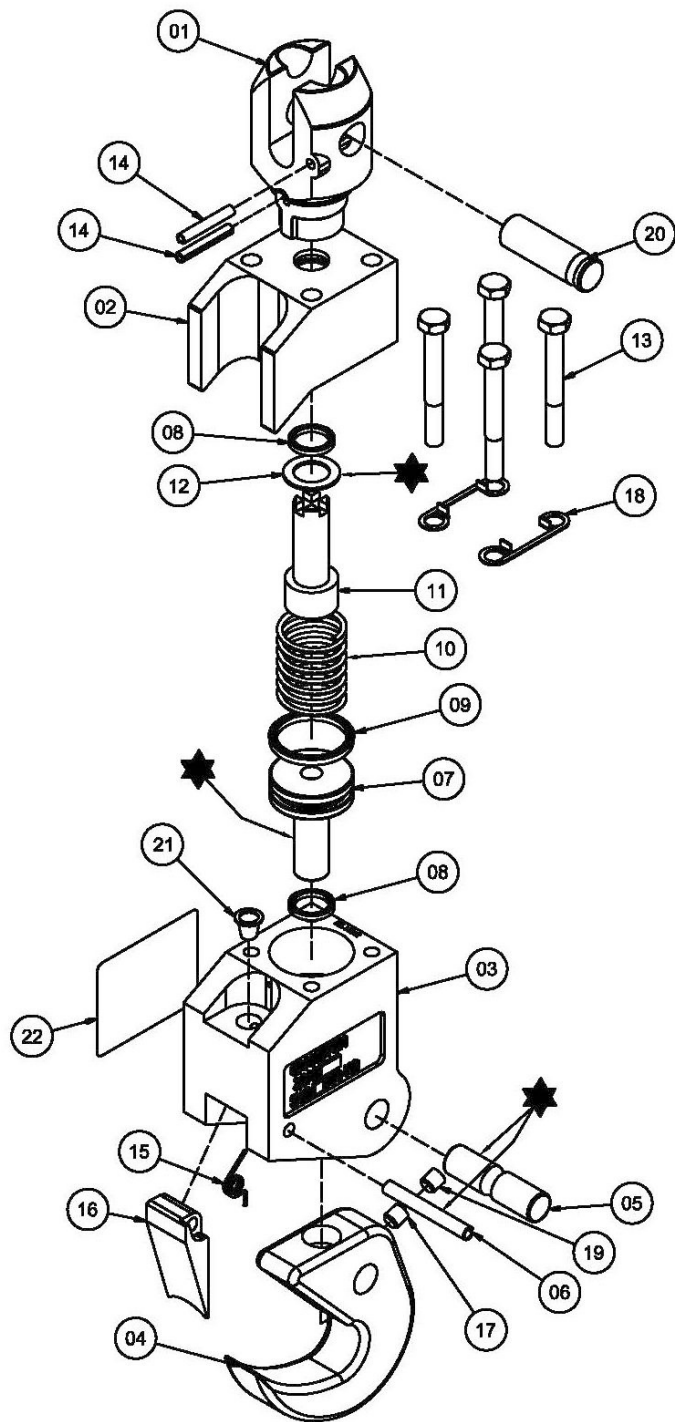

Product description and specification is subject to change without notice. All products and services are covered by Cranston standard terms and conditions, including limits of liability and warrantee effective at the time of sale. Available upon request. © Cranston Machinery Co., Inc.

Simplify Maintenance Simplify Maintenance Simplify Maintenance Simplify Maintenance Simplify Maintenance Simplify Maintenance Simplify Maintenance Simplify Maintenance Simplify Maintenance Simplify Maintenance
Raise Performance Raise Performance Raise Performance Raise Performance Raise Performance Raise Performance Raise Performance Raise Performance Raise Performance Raise Performance

Please visit us at: cranston-machinery.com

Our phone number is: + 001 (503) 654-7751

Cranston Machinery Co. In. 2251 S.E. Oak Grove Blvd. Oak Grove, Oregon 97267