

Item / Qty / Part No. / Description

01	1	CB4226000	Swivel attachment
02	1	CA8709000	Top cap
03	1	CB6509000	Body
04	1	CB4425000	Hook
05	1	AA7842000	Hook pin
06	1	M69100002	• Latch pin
07	1	CA3139000	Piston
08	2	M57000001	• U-Cup seal
09	1	M57000002	• U-Cup seal
10	1	AB0080000	Spring
11	1	AA8777000	Swivel bolt
12	1	AA8778000	Swivel bolt washer
13	4	M30600005	• Tie bolt
14	2	M69100032	• Roll pin
15	1	AA4197000	• Spring latch
16	1	BB6654000	Latch
17	2	BB8401000	• Bolt locking tab
18	1	M30100013	Set screw
19	1	M30100013	Jam set screw
20	1	AA6223000	Chain pin
21	1	M24250049	Relief valve
22	1	AB0121000	Caution sticker
23	1	AA8191000	Spacer
24	1	M18500013	Tapered plug

• Recommended Spares

Warning- Only use #M30600005 Bolts. They are special high strength bolts. Do not substitute any other hex head bolts.

ATTENTION- Cranston assembles each hook using a NLGI #2, marine grade, calcium sulfonate base grease (Example: Lucas Marine Grease) which seals out water and inhibits corrosion. Any substitution must be NLGI #2, have a washout rating of less than 3% (typically Calcium Sulfonate or polymerized PTFE), and a viscosity of 120-220 cSt. Ensure grease not applied to threaded areas.

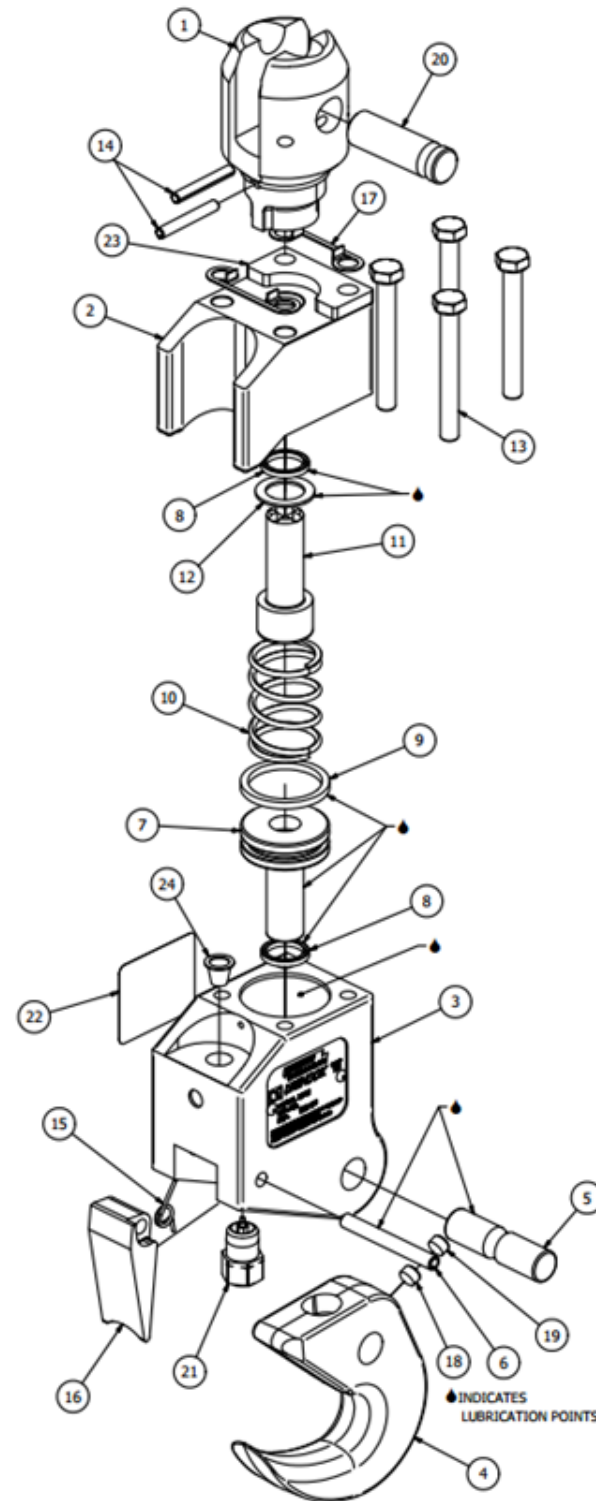

Product description and specification is subject to change without notice. All products and services are covered by Cranston standard terms and conditions, including limits of liability and warranty effective at the time of sale. Available upon request. © Cranston Machinery Co., Inc.

Bulletin No:	L051
UNIHOOK™ Model:	26A104
Issued:	220509
Patent No:	11434110

Introduction:

The Cranston UNIHOOK™ is a very robust, marine grade, lifting device, designed to provide remote release of a pre-slung load.

The user must assemble the UNIHOOK™ to a properly rated chain assembly and plumb to a pressurized, regulated air or nitrogen supply.

During attachment to a lifting sling (multiple wire strands, wire ropes, slings, rings, etc.), the pivoting hook is manually cocked in the locked position.

To unlatch the pivoting hook from the locked position, the load must be removed from the hook before the pneumatic supply is applied. For relocating slings, or other similar light load applications (up to 45Kg/100#), the pivoting hook can be released.

Limitation of Liability. Rigging, conditions of use, and maintenance of cargo handling gear is outside of Cranston Machinery Control. The user, therefore, must evaluate each application under the condition of use and the safety factor pertinent to the appropriate industry, to determine the safe application of the Cranston Machinery UNIHOOK™

Specifications:

- Safe Working Load: 3 Metric Tonnes
- Design Safety factor: 4 x SWL
- Certified Testing for each UNIHOOK™: 2 x SWL
- Operating Temperature: -35°C - +175°C
- Typical Weight: 5kg / 11#
- Guidelines for Maintenance, Use and Care: **CS005**
- Top Cap Features: **180 Degree rotation**
- Pivoting hook Material choice: **Corrosion Resistant**
- CE Compliance: Yes
- Tested for Underwater release: Yes

ATTENTION- All owners, users and technicians should review Cranston Specification CS005 prior to operation or servicing of this UNIHOOK™. CS005 is available thru Cranston's website. CS005 includes detail on use, maintenance, and warranty

WARNING- It is imperative that the pressurized pneumatic supply does not exceed .14MPa / 20PSI. An internal pressure relief valve is incorporated into this model UNIHOOK™ to audibly alert the user of an over pressure condition, indicating use should be discontinued, until the condition is corrected.

NOTE- Cranston Machinery would be pleased to consider any special requirements you may have. Cranston Machinery designs and manufactures custom tools, lift beams and automated equipment.

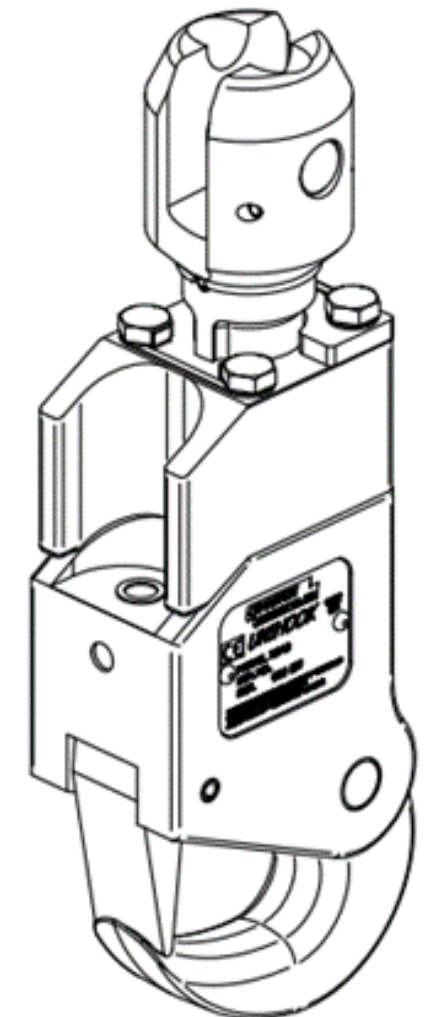

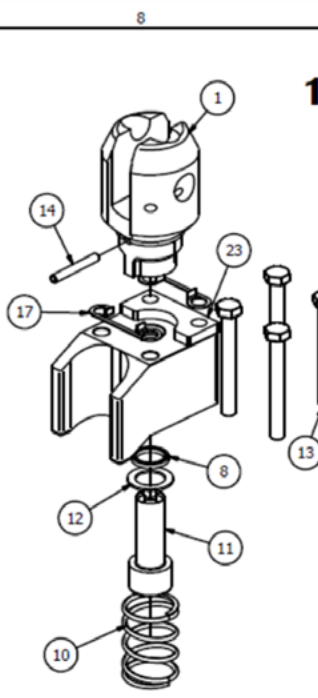

- 1** DISASSEMBLE TOP CAP SECTION OF HOOK:
- CLEAN HOOK EXTERIOR BEFORE DISASSEMBLY.
 - FLATTEN LOCK TABS #17, LOOSEN AND REMOVE TIE BOLTS #13.
 - REMOVE TOP CAP FROM BODY AND PLACE SPRING #10, ROTATION SPACER #23 (IF APPLICABLE) AND BODY IN A CLEAN CONTAINER.
 - USE A $\frac{3}{16}$ " FLAT BOTTOM PUNCH TO REMOVE COIL PIN #14 FROM SWIVEL ATTACHMENT #1.
 - PLACE SWIVEL ATTACHMENT #1 IN A NON-MARRING VICE (OR EQUIVALENT FIXTURE).
 - USE A 1/2" ALLEN WRENCH TO REMOVE SWIVEL BOLT #11 AND WASHER #12. PLACE IN CLEAN CONTAINER.
 - USE A SMALL PLASTIC OR BRASS PIC TO REMOVE SEAL #8. BE VERY CAREFUL TO NOT SCRATCH SEAL LAND.

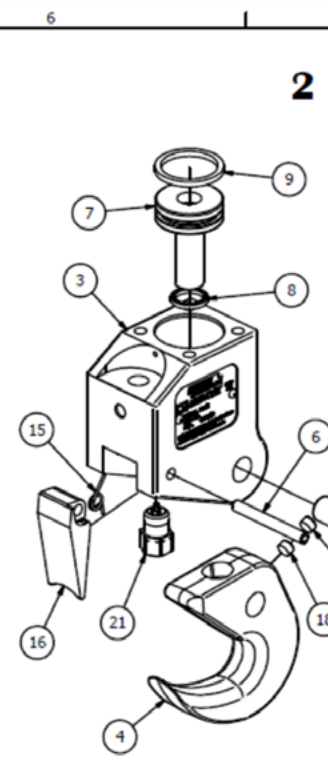

- 2** DISASSEMBLE PNEUMATIC SECTION OF HOOK:
- USE A $\frac{5}{16}$ " ALLEN WRENCH TO REMOVE JAM SET SCREW AND #18 SET SCREW.
 - HOOK PIN SHOULD SLIDE OUT RELEASING HOOK. IF PIN DOES NOT SLIDE OUT BY HAND, DETERMINE IF REPLACING PIN IS APPLICABLE.
 - USE A 1/4" PUNCH TO TAP LATCH PIN #6 OUT OF BODY #3. CAREFUL NOT TO LOSE LATCH SPRING #15.
 - PRESS ON ROD END OF PISTON #7 AND REMOVE FROM BODY #3.
 - USE A PLASTIC OR BRASS PIC TO DELICATELY REMOVE BOTH PISTON SEAL #9 AND ROD SEAL #8. CAREFUL NOT TO SCRATCH LANDS.
 - THE PRESSURE RELIEF VALVE IS NOT A SERVICEABLE ITEM AND SHOULD BE REPLACED IF LEAK IS DETECTED BELOW 25PSI. IF VALVE IS TO BE REUSED, IT SHOULD BE REMOVED AND GENTLY CLEANED WITH MINERAL OIL.
- CLEAN AND INSPECT:
- PLACE ALL HOOK COMPONENTS IN A CONTAINER OF CLEAN MINERAL SPIRITS OVERNIGHT.
 - WITH A NYLON PARTS BRUSH CLEAN ALL SURFACES AND PLACE ON A CLEAN TOWEL.
 - USE SHOP AIR TO DRY ALL INTERIOR SURFACES.
 - INSPECT ALL FOLLOWING AREAS FOR SCRATCHES, ELONGATION OR DAMAGE.
 - A) CYLINDER BORE AND ROD SEAL LAND.
 - B) PISTON ROD AND SEAL LAND.
 - C) SWIVEL ATTACHMENT PIN BORE AND PIN.
 - D) HOOK BORE AND PIN IN BOTH HOOK AND BODY.
 - E) LATCH BORE AND BODY LATCH BORE.

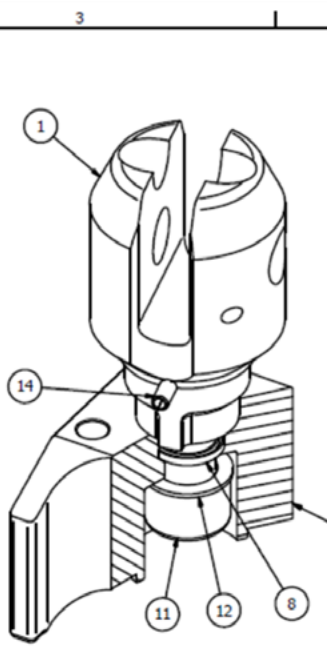

- 3** ASSEMBLE SWIVEL / TOP CAP ASSEMBLY:
- INSTALL NEW "U" SEAL #8 INTO TOP CAP #2 WITH "U" TOWARDS TOP OF TOP CAP.
 - SMEAR INSIDE LIP OF INSTALLED "U" SEAL #8 WITH LUCAS MARINE GREASE.
 - APPLY LUCAS MARINE GREASE TO BOTH SIDES OF WASHER #12, PLACE ON BOLT #11.
 - TIGHTEN BOLT #11 THRU TOP CAP #2 TO SWIVEL ATTACHMENT #1 TO FINGER TIGHT, THEN BACK OFF TILL THE FIRST AVAILABLE SLOT ALIGNS FOR ROLL PIN HOLE WITH SLOT IN SWIVEL BOLT #11.
 - CHECK FOR MAXIMUM CLEARANCE OF .022" BETWEEN #1 AND #2
 - INSTALL ROLL PIN #14.

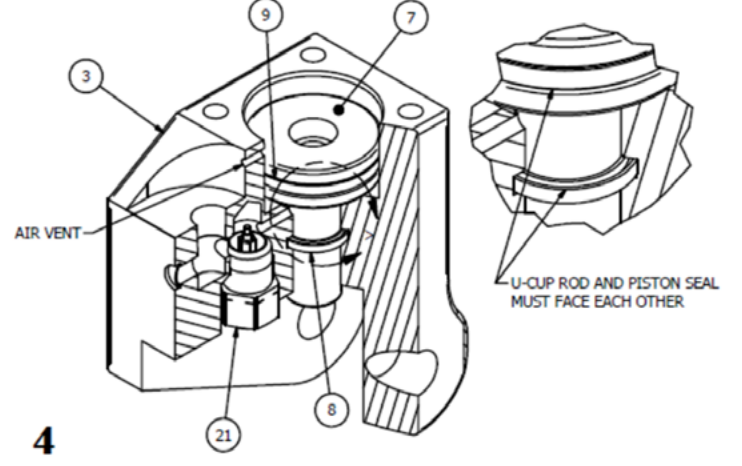

- 4** PISTON / BODY ASSEMBLY:
- INSPECT INTERNALS OF BODY #3 SEAL GROVE AND AIR PATH AND VENT FOR CONTAMINATES. CONFIRM BORE IS CLEAN AND FREE OF IMPERFECTIONS.
 - APPLY THREAD SEALANT TO PRESSURE RELIEF VALVE* #21. CAREFUL TO AVOID SEALANT AROUND VALVE INTERNALS. HAND THREAD VALVE INTO BODY #3, TIGHTEN WITH SOCKET WRENCH ONE TO TWO TURNS MORE. CONFIRM VALVE IS RECESSED BELOW BODY SURFACE.
 - INSTALL "U" SEAL #8 IN ROD BORE OF BODY #3, WITH "U" UP TOWARDS PISTON BORE.
 - INSTALL "U" SEAL #9 ON PISTON #7 WITH "U" TOWARDS ROD END.
 - APPLY A THIN LAYER OF LUCAS MARINE GREASE TO OUTER LIP OF "U" SEAL #9 AND INNER LIP OF "U" SEAL #8 IN BODY.
 - SMEAR A THIN LAYER OF LUCAS MARINE GRADE GREASE ON THE ENTIRE BORE SURFACE AND THE FIRST THIRD OF PISTON #7 ROD.
 - INSTALL PISTON #7 INTO BODY #3 USING SEAL COMPRESSION FIXTURE TOOL BB9695. NOTE: PISTON SHOULD MOVE FREELY AND WITH PISTON DOWN IN THE BORE, THERE SHOULD BE 7/16 MIN. FROM TOP OF PISTON TO TOP OF CYLINDER BODY.

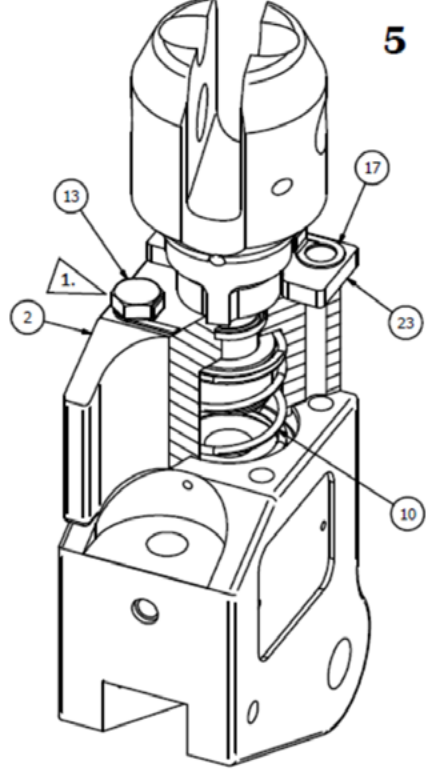

- TOP CAP TO BODY ASSEMBLY:
- PLACE SPRING #10 ON PISTON AND INSTALL SWIVEL/ TOP CAP ASSEMBLY ON PISTON BODY ASSEMBLY.
 - INSERT TWO BOLTS #13 WITH ONE LOCK TAB #17 THRU BODY ON INLET PORT SIDE AND LOOSELY THREAD.
 - POSITION ROTATION STOP SPACER #23 (IF APPLICABLE) OPPOSITE THE INLET PORT AND TAB ON SWIVEL ATTACHMENT FACING PORT. INSERT NEXT TWO BOLTS #13 WITH ONE LOCK TAB #17 THRU SPACER AND THREAD INTO BODY.
 - TIGHTEN #13 BOLTS IN CROSS PATTERN TILL SNUG.
 - PRELIMINARY TEST WITH 20 PSI AIR, PISTON SHOULD MOVE FREELY, SUBMERGE BODY INTO WATER AND CHECK FOR AIR LEAKS. NOTE: IF AIR LEAKS, DISASSEMBLE, CHECK U-CUP SEALS #8 AND #9 FOR DAMAGE, CHECK BODY #3 FOR SCRATCHES IN SEAL LANDS. THEN REASSEMBLE AND RETEST.
 - INCREASE PRESURE, AT 25 PSI AND ABOVE AIR ESCAPE OUT PRESSURE RELIEF VALVE. IF NOT VALVE SHOULD BE REPLACED WITH NEW.
 - TORQUE #13 BOLTS IN A CROSS PATTERN TO 24-29 FT-LBS (3.32-4.01 KG-M). MAKE SURE A FLAT ON EACH BOLT IS ALIGNED WITH A LOCK TAB AND THEN BEND UP LOCK TAB AGAINST BOLT HEAD.

1. WARNING! ONLY USE THE M30600005 BOLTS. THEY ARE SPECIAL HIGH STRENGTH BOLTS. DO NOT SUBSTITUTE ANY OTHER HEX HEAD BOLTS.

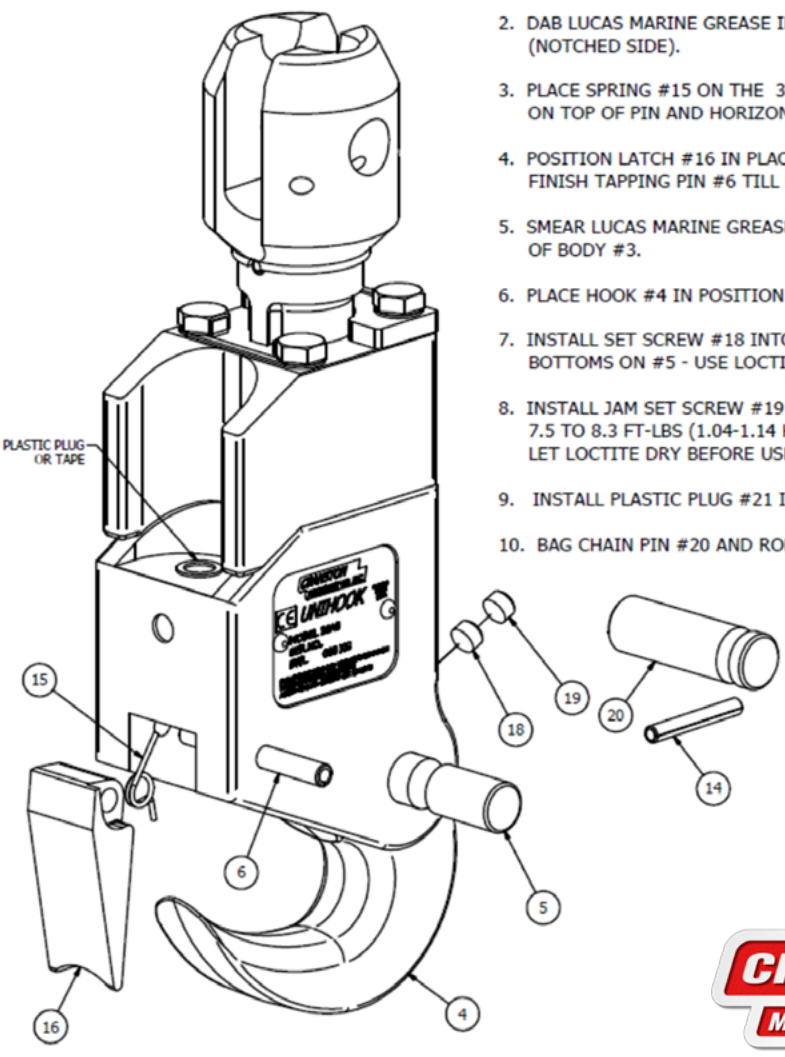

- 6** HOOK & LATCH ASSEMBLY:
- TAP PIN #6 INTO BODY #3 (THRU SER. PLATE SIDE) $\frac{3}{4}$ " (APPX. 3/16" INTO CAVITY).
 - DAB LUCAS MARINE GREASE IN HOLE OF LATCH #16 (NOTCHED SIDE).
 - PLACE SPRING #15 ON THE 3/16" OF PIN #6, LONG TANG ON TOP OF PIN AND HORIZONTAL TO HOOK.
 - POSITION LATCH #16 IN PLACE AGAINST SPRING #15, AND FINISH TAPPING PIN #6 TILL FLUSH.
 - SMEAR LUCAS MARINE GREASE IN THE TWO 9/16" HOLES OF BODY #3.
 - PLACE HOOK #4 IN POSITION AND SLIDE IN PIN #5 TILL FLUSH.
 - INSTALL SET SCREW #18 INTO HOOK #4, TIGHTEN UNTIL IT BOTTOMS ON #5 - USE LOCTITE 242.
 - INSTALL JAM SET SCREW #19 INTO HOOK #4 AND TORQUE 7.5 TO 8.3 FT-LBS (1.04-1.14 KG-M). USE LOCTITE 242. LET LOCTITE DRY BEFORE USE.
 - INSTALL PLASTIC PLUG #21 IN PORT.
 - BAG CHAIN PIN #20 AND ROLL PIN #14 FOR STORAGE / INSTALLATION

